

freeway

SA180C



Weights and dimensions

SWL	: 180 kg
Unit weight	: 52 kg
A (height)	: 925 – 1,570 mm
B (length)	: 882 mm
C (internal width)	: 413 – 812 mm
D (external width)	: 541 – 939 mm
E (ground clearance)	: 50 mm
F (under bed clearance)	: 134 mm
G (Kneepad height)	: 350 – 500 mm
Turning circle	: 915 mm
Castor size	: 75 mm

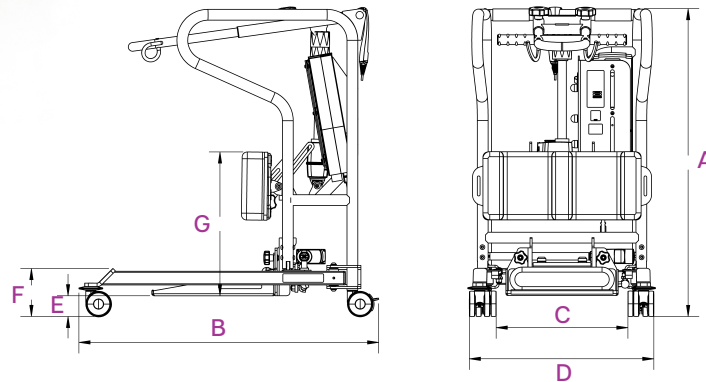

Details

Product code	: 1301SA-SA180C
Drawing number	: 119200
GS1 code	: 5056408920100
Warranty	: 3 years
Sling connection	: Looped
Lift	: Electric (LA40 – 8 kN)
Leg opening	: Electric (LA23 – 1.5 kN)
Handset controls	: Wired electric hooked handset
Control box	: Standard (with LCD screen)
Foot tray	: Removable (5 kg)
Duty cycle	: 15% use, 85% rest
Battery	: 24 V SLA, 2.9 Ah
Charging time	: 8 hours
Lifts per charge	: 30
IP rating (controls)	: IPX4
IP rating (battery)	: IPX5
Material	: Powdercoated steel, PU foam, vinyl PVC

Standards

ISO 10535:2006
 IEC 62366-1:2015
 EN ISO 15223-1:2016
 IEC 60601-1:2012
 IEC 60601-2:2014

Contact

Unit 4 Jubilee Way
 Grange Moor
 Wakefield
 United Kingdom
 WF4 4TD

This product is CE marked and
 complies with EU MDR 2017/745

+44 (0)1924 840100
 info@prismmedical.co.uk

