

**Weights and dimensions**

SWL	: 180 kg
Unit weight	: 40 kg
Base weight	: 18.5 kg
Mast and boom weight	: 21.5 kg
A (height)	: 1,340 – 2,010 mm
B (length)	: 1,235 mm
C (internal width)	: 500 – 1,100 mm
D (external width)	: 620 – 1,150mm
E (ground clearance)	: 15 mm
F (under bed clearance)	: 100 mm
G (Carry bar height)	: 380 – 1,750 mm
Carry bar width	: 620 mm
Turning circle	: 1,010 mm
Castor size (front, back)	: 75, 100 mm

**Details**

Product code	: 1301MH-ESS180
Drawing number	: 123400
GS1 code	: 5056408920322
Warranty	: 1 year
Sling connection	: Looped
Lift	: Electric (LA40 – 8 kN)
Leg opening	: Electric (LA23 – 2.5 kN)
Hand controls	: Wired electric hooked handset
Control box	: Standard (no screen)
Duty cycle	: 15% use, 85% rest
Battery	: 24 V SLA, 2.9 Ah
Charging time	: 8 hours
Lifts per charge	: 30
IP rating (controls)	: IPX4
IP rating (battery)	: IPX5
Material	: Powdercoated steel, vinyl PVC

**Standards**

- ISO 10535:2006
- IEC 62366-1:2015
- EN ISO 15223-1:2016
- IEC 60601-1:2012
- IEC 60601-2:2014

This product is CE marked and complies with EU MDR 2017/745

**Contact**

Unit 4 Jubilee Way  
Grange Moor  
Wakefield  
United Kingdom  
WF4 4TD

+44 (0)1924 840100  
info@prismmedical.co.uk

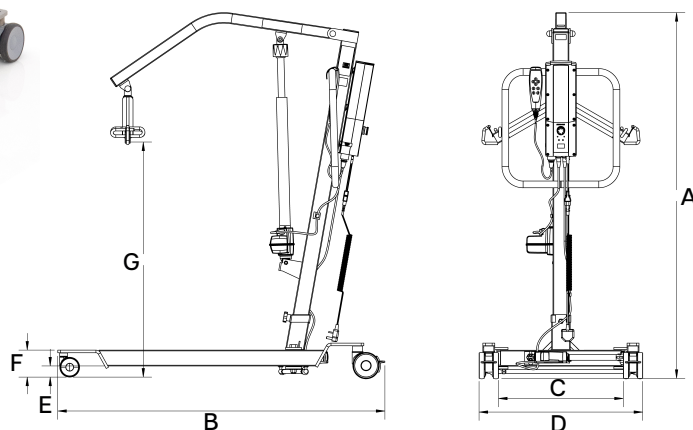

# 180 (QRS)

## Weights and dimensions

SWL	: 180 kg
Unit weight	: 40 kg
Base weight	: 18.5 kg
Mast and boom weight	: 21.5 kg
Carry bar weight	: 2 kg
A (height)	: 1,340 – 2,010 mm
B (length)	: 1,235 mm
C (internal width)	: 500 – 1,100 mm
D (external width)	: 620 – 1,150mm
E (ground clearance)	: 15 mm
F (under bed clearance)	: 100 mm
G (Carry bar height)	: 380 – 1,750 mm
Carry bar width	: 615 mm
Turning circle	: 1,010 mm
Castor size (front, back)	75, 100 mm

## Details

Product code	: 1301MHQRS123401
Drawing number	: 123401
GS1 code	: 5056408924337
Warranty	: 1 year
Sling connection	: Looped
Lift	: Electric (LA40 – 8 kN)
Leg opening	: Electric (LA23 – 2.5 kN)
Hand controls	: Wired electric hooked handset
Control box	: Standard (no screen)
Duty cycle	: 15% use, 85% rest
Battery	: 24 V SLA, 2.9 Ah
Charging time	: 8 hours
Lifts per charge	: 30
IP rating (controls)	: IPX4
IP rating (battery)	: IPX5
Material	: Powdercoated steel, PU foam

## Standards

ISO 10535:2006  
IEC 62366-1:2015  
EN ISO 15223-1:2016  
IEC 60601-1:2012  
IEC 60601-2:2014

This product is CE marked and complies with EU MDR 2017/745

## Contact

Unit 4 Jubilee Way  
Grange Moor  
Wakefield  
United Kingdom  
WF4 4TD

+44 (0)1924 840100  
info@prismmedical.co.uk

